

PET3040CJ

Water Cooled Triode
For Industrial RF Heating

Drop in equivalent of RS 3040 CJ

- Output Power: 60 kW (CW mode)
- Anode voltage: 14 kV
- Anode dissipation: 32 kW
- Frequency up to 100 MHz

Manufactured in India, in a world-class facility equipped with high quality machinery, materials and components sourced from reputed suppliers in America, Europe and Japan.

Fifty-two weeks warranty against manufacturing defects irrespective of the number of hours of operation.



PET3040CJ

The PET3040CJ is a RF power triode designed for dielectric heating applications such as textile, food and paper drying. This tube uses a coaxial design and metal-ceramic technology. This triode may be operated in CW or pulse modes. Parameters for operation in pulse mode depend on each equipment characteristics. Contact us for specific information. The PET3040CJ is a water cooled triode.

Electrical characteristics

Cathode Filament	thoriated tungsten
Filament voltage	8 V
Filament current	185 A
Surge current (maximum)	560 A
Capacitances:						
• Grid to Anode	29 pF
• Grid to Cathode	78 pF
• Cathode to Anode (see note 2)	2 pF
Amplification factor	20

Mechanical characteristics

Operating position	vertical
Weight	8.5 kg (18.7 lbs) approx.
Dimensions	150 x 368 mm

Cooling

Anode cooling	Industrial Water
Maximum water temperature at tube outlet.	55 °C
Minimum water pressure at tube inlet.	6 bar
Maximum temperature at any point on the tube envelop.	220 °C
Min. air flow on filament connections	1 m3/min

Maximum ratings

Frequency	120 MHz
Anode voltage:						
• Up to 30 MHz	14 kV
• From 30 to 50 MHz	10 kV
• From 50 to 100 MHz	7.5 kV
Control grid voltage	-1500 V
Control grid current:						
• At full load up to 30 MHz	1.6 A
• At off load up to 30 MHz	1.9 A
Cathode current.	12 A
Anode dissipation	35 kW
Grid dissipation:						
• Up to 30 MHz	820 W
• From 30 to 50 MHz	700 W
• From 50 to 100 MHz	600 W
Grid resistance	12 K Ω

Class C RF oscillator for industrial applications

Frequency	<30	<30	MHz
Anode voltage	12	12	kV
Anode current	6.3	5.2	A
Anode input power	76	62.4	kW
Anode output power	60	50	kW
Anode dissipation	14	11	kW
Grid current, on load	1.2	1	A
Grid dissipation	470	350	W
Grid resistance	920	1000	Ω
Feedback ratio	14.5	12.7	%
Oscillator efficiency	79	80	%

Operations at higher frequencies available upon request

Constant Current Characteristics

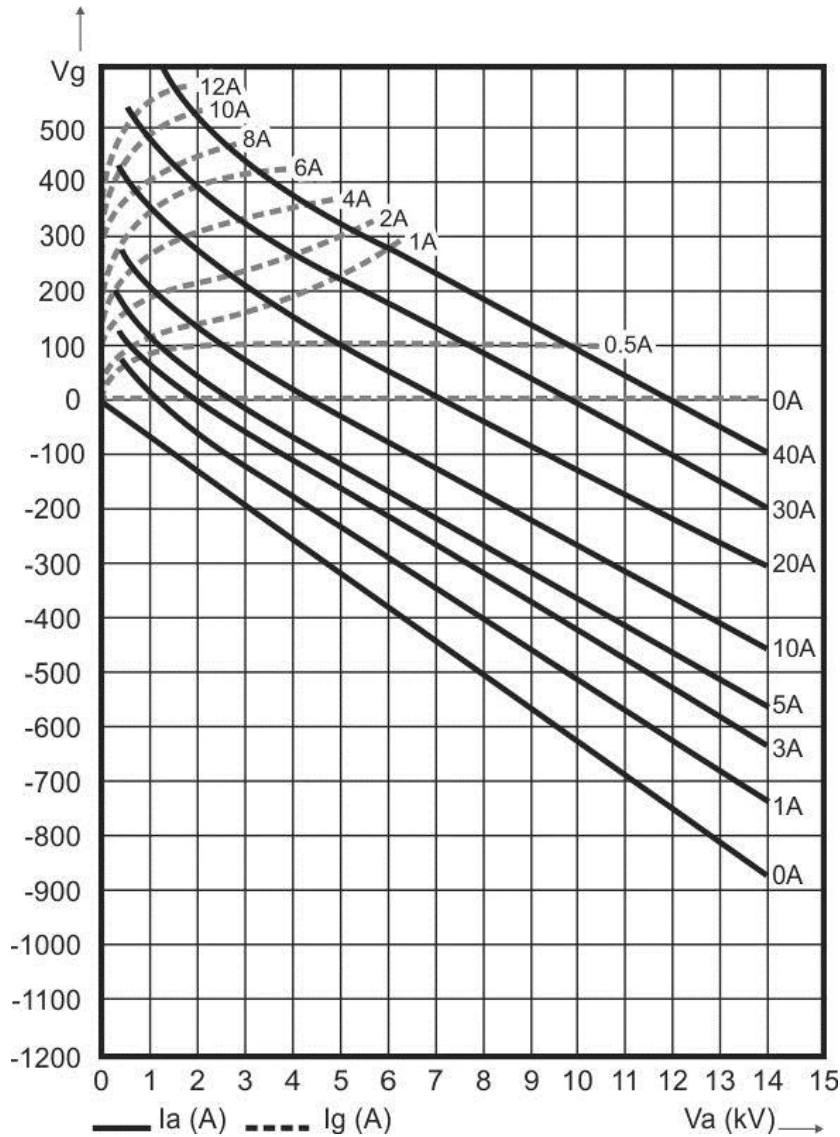

Outline Drawing (in mm)

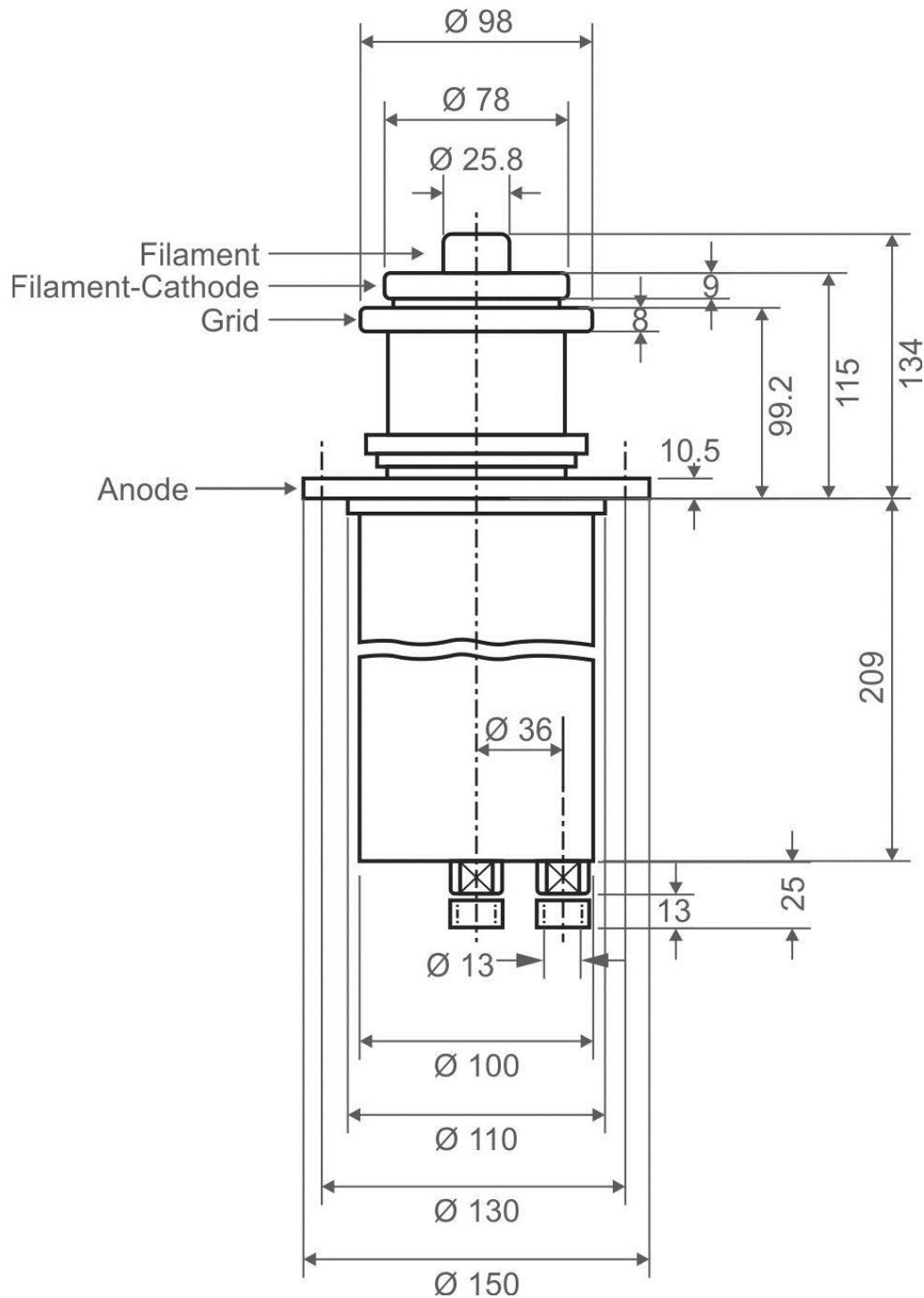

This document cannot be considered to be a contractual specification. The information given herein may be modified without notice due to product improvement or further development. Consult Piani Electron Tubes and Devices before making use of this information for equipment design.