

# PET3CX5000H3

Air Cooled Triode  
For Industrial RF Heating

Drop in equivalent of 3CX5000H3

- Output Power: 18 kW
- Anode voltage: 10 kV max
- Anode dissipation: 5 kW max
- Frequency: 90 MHz max

Manufactured in India, in a world-class facility equipped with high quality machinery, materials and components sourced from reputed suppliers in America, Europe and Japan.

Fifty-two weeks warranty against manufacturing defects irrespective of the number of hours of operation.

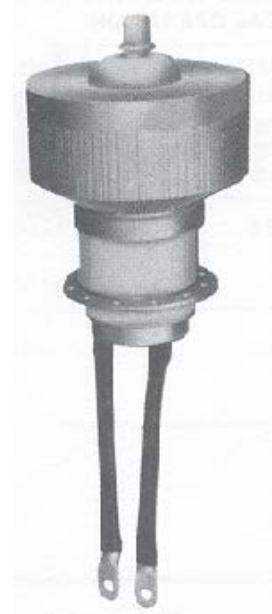

# PET3CX5000H3

Forced air-cooled, ceramic/metal power triode with a robust mesh filament, for use in industrial radio-frequency heating

## Electrical Characteristics

Filament								thoriated tungsten
Filament voltage (see note 1)							7.5	V
Filament current							75	A
Surge Filament current (peak) (see note 2)							375	A
Filament cold resistance.							11.8	mΩ
Peak usable cathode current							20	A
Amplification factor							20	
Inter – electrode capacitances:								
Grid to anode							27	pF
Grid to filament							54	pF
Anode to filament							1.8	pF

## Mechanical Characteristics

Connections								Filament leads and grid contact flanges
Operating position								vertical, either way up
Maximum operating temperature							250	°C
Maximum dimensions								See outline drawing
Net weight								4.7 kg (10 pounds) approx

## Accessories

Cathode connector . . . . . CWPA830  
For frequencies above 2MHz, CWPA830 should be used in conjunction with a strip connection to provide a low inductance cathode return.

## Cooling

Sufficient air must be passed through the radiator to keep the temperatures of the ceramic to metal seals and of the anode (measured next to the radiator) below the maximum rated value of 250 °C. The air flows required to maintain seal temperature at 225 °C in an ambient temperature of 50 °C and with an operating frequency of less than 30 MHz are shown in the following table.

An additional air flow is required for the filament seals. 8ft<sup>3</sup>/min directed at the centre contact ring, ½ inch below the outer contact ring, through a 1 ½ inch internal diameter air duct at 45 °C to the axis of the tube, is sufficient for operation up to 30 MHz at 50 °C ambient and 5000 ft altitude.

## Minimum Radiator Air Flow Requirements

Anode Dissipation Watts	Sea Level		5000 Feet	
	Air Flow ft <sup>3</sup> /min	Drop inches Water	Air Flow ft <sup>3</sup> /min	Drop inches Water
4000	98	0.24	118	0.29
5000	152	0.49	182	0.59
6000	236	1.00	283	1.20

The values given allow for maximum filament and grid dissipation in addition to the anode dissipation shown.

**Radio Frequency Oscillator For Industrial Service**

(Class C Conditions, One Tube)

**Maximum Ratings (Absolute Values)**

Frequency	90	MHz max
Anode voltage d.c.	10	kV max
Anode current d.c. (see note 3)	3.0	A max
Anode input power	25	kW max
Anode dissipation	5	kW max
Grid voltage d.c.	-1000	V max
Grid current d.c.(see note 4)	0.5	A max
Grid dissipation	150	W max
Cathode current d.c.	4.0	A max

**Typical Operating Conditions**

Frequency	30	30	MHz
Anode voltage d.c.	7.0	9.0	kV
Anode current d.c.	2.65	2.52	A
Anode dissipation	4.1	4.1	kW
Grid voltage d.c.	-700	-900	V
Grid resistor	3650	4900	Ω
Grid current d.c..	192	184	mA
Grid dissipation	44	42	W
Drive power	179	208	W
Anode input power	18.6	22.7	kW
Anode output power	14.5	18.6	kW
Output power less drive	14.3	18.4	

**Notes**

1. The filament voltage measured at the tube should be 7.5 V ± 5% for satisfactory performance, maximum life is obtained at -5% (7.1 V).
2. The filament current must not exceed 375 A, even momentarily, at any time.
3. Maximum anode voltage and current should not be applied simultaneously; this could result in excessive anode dissipation. The anode supply should include current-limiting resistors, and an over-current trip to remove anode voltage quickly in the event of an overload or arc (such load variations and faults are common in industrial service). Spark gaps should be connected between anode and ground, to protect the tube from voltage transients under fault conditions.
4. The grid current rating of 0.5 A of d.c. should not be exceeded, except for very short periods during tuning. Normally, reasonable efficiency can be obtained with a grid current not exceeding 0.25 A. The grid circuit should include over-current protection, and d.c. grid current should be monitored continuously during industrial operation with varying loads.

## Health And Safety Hazards

PET electronic devices are safe to handle and operate, provided that the precautions stated are observed. PET does not accept responsibility for damage or injury resulting from the use of electronic devices it produces. Equipment manufacturers and users must ensure that adequate precautions are taken. Appropriate warning labels and notices must be provided on equipments incorporating PET devices and in operating manuals.



### High voltage

Equipment must be designed so that personnel cannot come into contact with high voltage circuits. All high voltage circuits and terminals must be enclosed and fail-safe interlock switches must be fitted to disconnect the primary power supply and discharge all high voltage capacitors and other stored energy before allowing access. Interlock switches must not be bypassed to allow operation with access doors open.



### R.F. Radiation

Personnel must not be exposed to excessive r.f. radiation. A properly designed equipment cabinet with good r.f. electrical connection between panels will normally provide sufficient protection.



### X-Ray Radiation

This device, when operating at voltages above 5 kV, produces progressively more dangerous X-rays as the voltage is increased, the radiation varies greatly during life. The device envelope provides only limited protection and further shielding may be required. A metal equipment cabinet with overlapping joints will usually provide sufficient shielding, but if there is any doubt an expert in this field should perform an X-ray survey of the equipment.



### Implosion

This tube stores potential energy by virtue of its vacuum. The energy level is low, but there is some hazard from flying fragments if the tube is dropped or subjected to violent impact. The tube must be stored and transported in its approved pack. During installation or replacement the tube must not be scratched or damaged in any way likely to reduce the strength of the ceramic envelope.

# TYPICAL CONSTANT CURRENT CHARACTERISTICS OF PET3CX5000H3

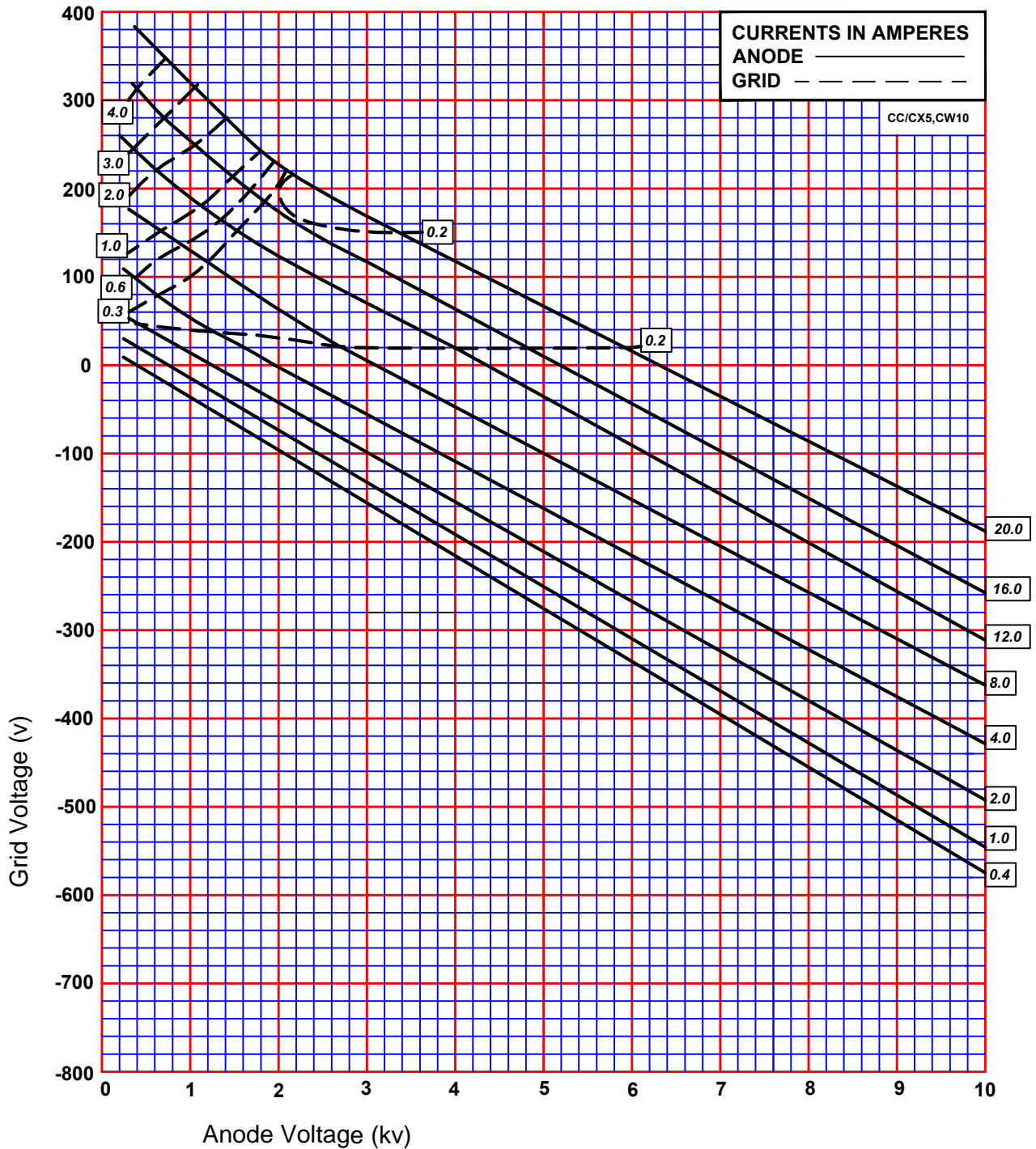

# OUTLINE OF PET3CX5000H3

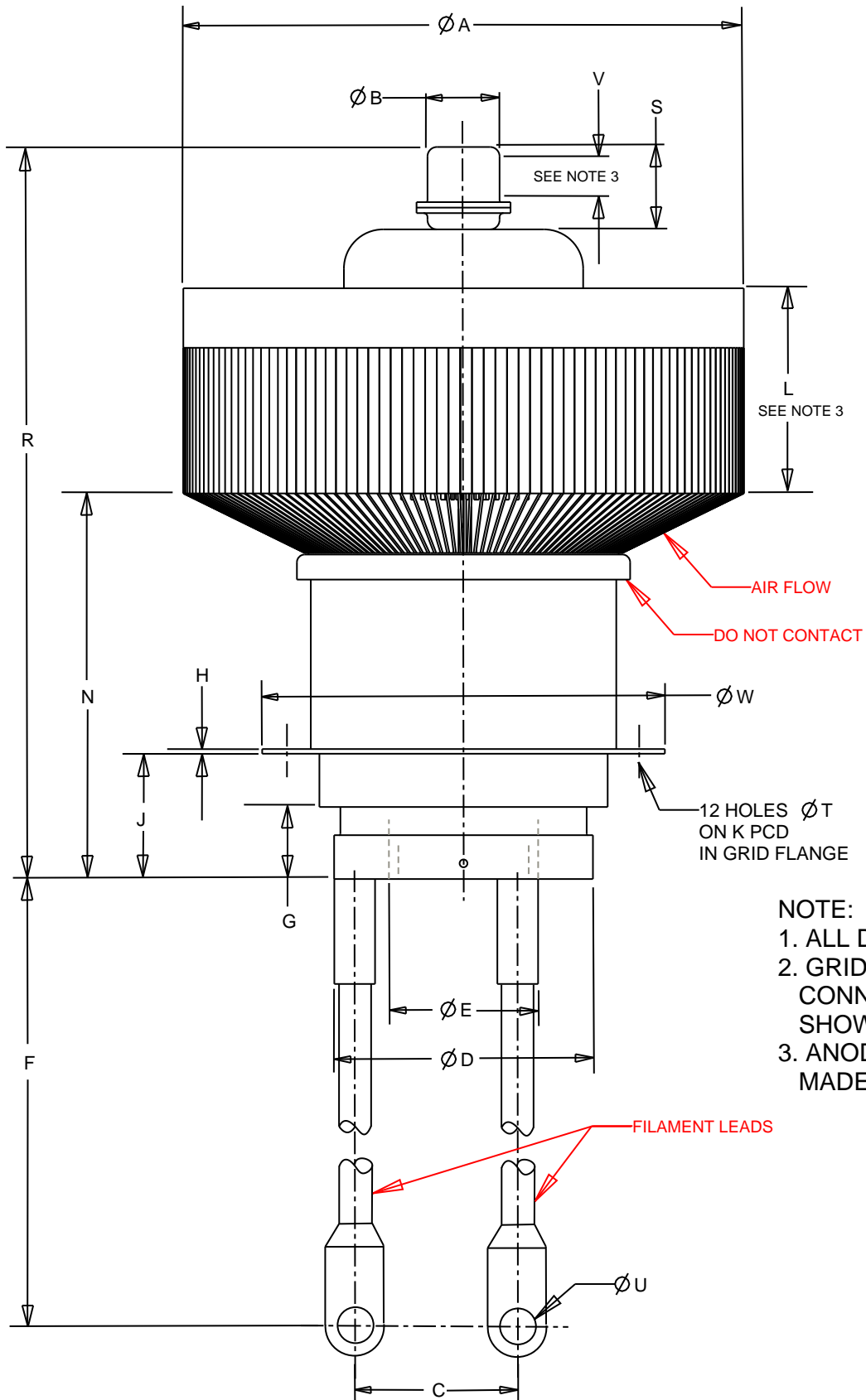

REF.	MILLIMETRES
A	161.29 ±1.27
B	22.50 ±0.50
C	52.04
D	82.60
E	47.63
F	209.55 ±6.35
G	23.00
H	01.50
J	40.00 ±1.0
K	112.65 ±0.25
L	65.50 ±5.0
N	122.5 ±2.5
P	47.63
R	225.50 ±5.0
S	26.30
T	06.35
U	9.91
V	9.53 MIN
W	128.52 ±0.76

**NOTE:**

1. ALL DIMENSIONS ARE IN MM.
2. GRID FLANGE, FILAMENT CONNECTIONS ORIENTATED AS SHOWN.
3. ANODE CONNECTION MAY BE MADE TO THIS SURFACE